

# Using the UCC28070EVM

## User's Guide



Literature Number: SLUU312  
May 2008

# **UCC28070 300-W Interleaved PFC Pre-Regulator User's Guide**

---

---

---

## **1 Introduction**

The UCC28070 evaluation module is a 300-W, two phase interleaved, PFC pre-regulator that uses average current mode control techniques to achieve near unity power factor. The pre-regulator was designed to operate off a universal ac line input of 85 V to 265 V and provides a regulated 390-V dc output. This evaluation module demonstrates TI's interleaved PFC control technology.

## **2 Description**

The pre-regulator uses the UCC28070 PFC interleaved controller to shape the input current wave form to provide power factor correction.

## **3 Thermal Requirements**

- The evaluation module works up to 300 W without external cooling in ambient temperature of 25°C.

## **4 Electrical Specifications**

**Table 1. Specification Table**

<b>DEFINITION</b>	<b>MINIMUM</b>	<b>TYPICAL</b>	<b>MAXIMUM</b>	<b>UNITS</b>
RMS Input Voltage (ac line)	85		265	V
Output Voltage ( $V_{OUT}$ )		390		
Line Frequency	47		63	Hz
Power Factor (PF) at Maximum Load	0.9			
Output Power			300	W
Full Load Efficiency	90			%

## 5 Schematics

To evaluate inductor ripple currents jumpers JP1 and JP2 can be removed and replaced with current loops.

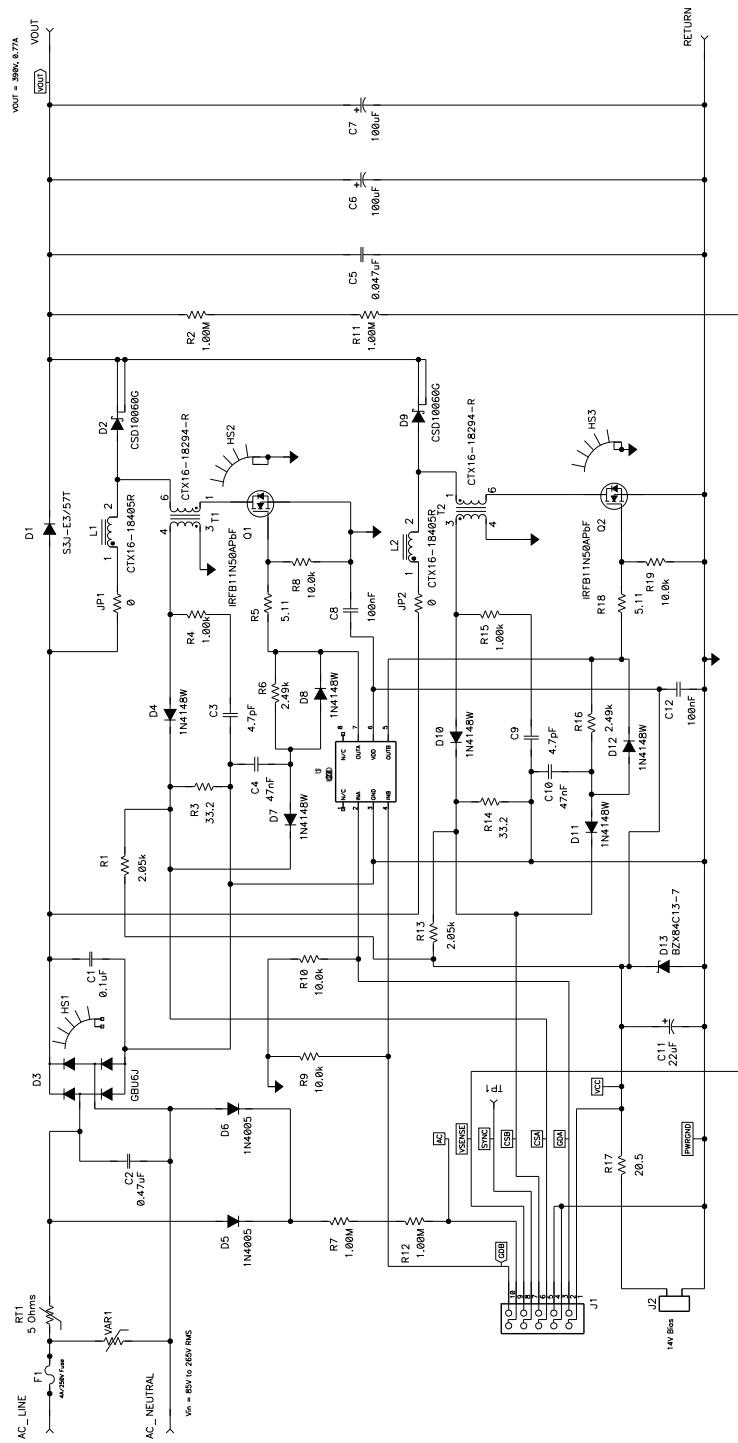

Figure 1. Interleaved PFC Power Stage (Mother Board HPA225)

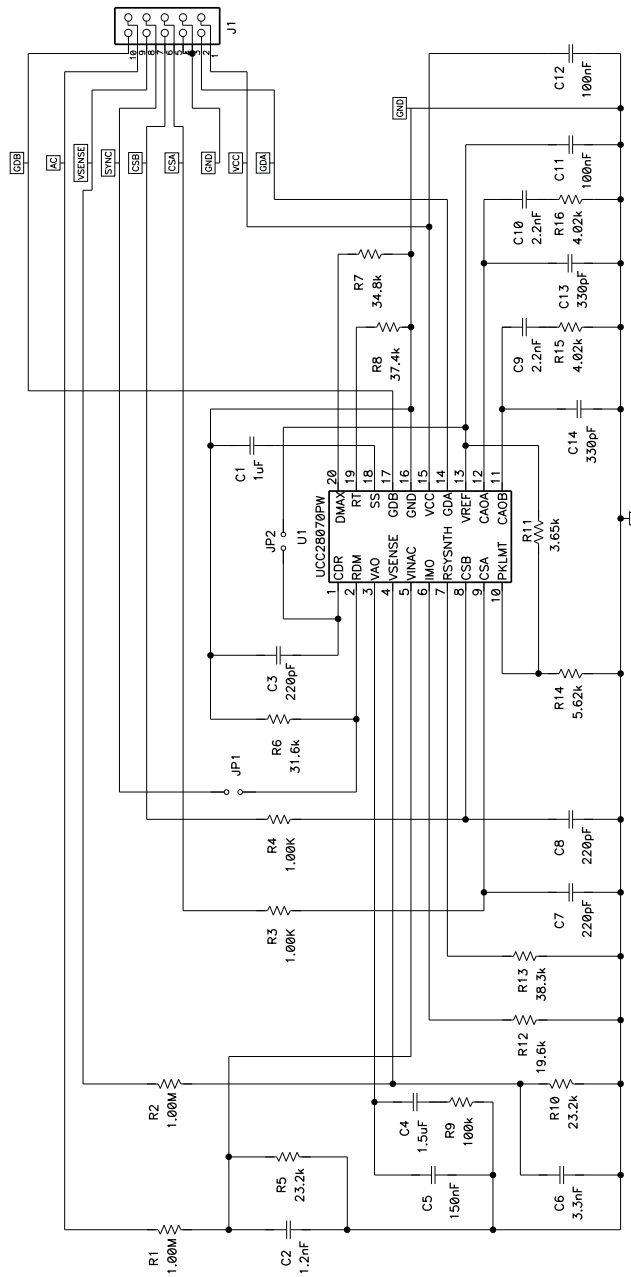

Figure 2. Controller Circuitry (Daughter Board HPA284)

## 6 Warning

There are high voltages present on the pre-regulator and it should only be handled by experienced power supply professionals. To evaluate this board as safely as possible the following test set up should be used. An isolation transformer should be connected between the source and unit. Before power is supplied a voltmeter and a resistive or electronic load should be attached to the unit's output.

## 7 Test Setup and Power Up/Power Down Instructions

A separate 14-V bias supply is required to power the UCC28070 control circuitry. The unit will start up under no load conditions. However, for safety, a load should be connected to the output of the device before it is powered up. It is advised that resistive loads be used. Constant current or constant power loads could damage the evaluation board. The unit should also never be handled when power is applied to it or the output voltage is above 50-V dc. Please refer to [Figure 3](#) for the test setup diagram.

**Note:** There are very high voltages on the board and components can and will reach temperatures above 100 °C, so caution must be taken in handling the board.

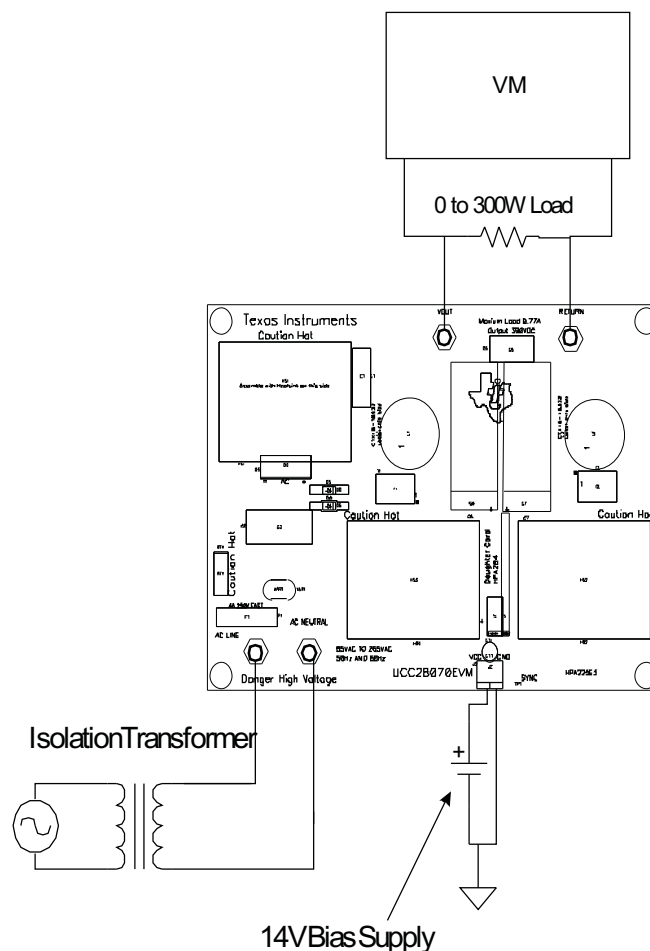

Figure 3. Test Setup

8 Performance Data

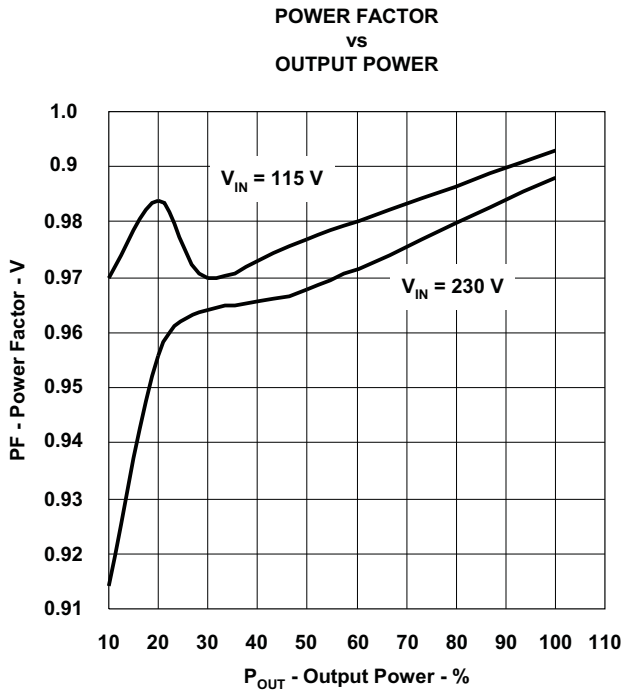

Figure 4. Power Factor at  $V_{IN} = 115\text{ V}$  and  $230\text{ V RMS}$

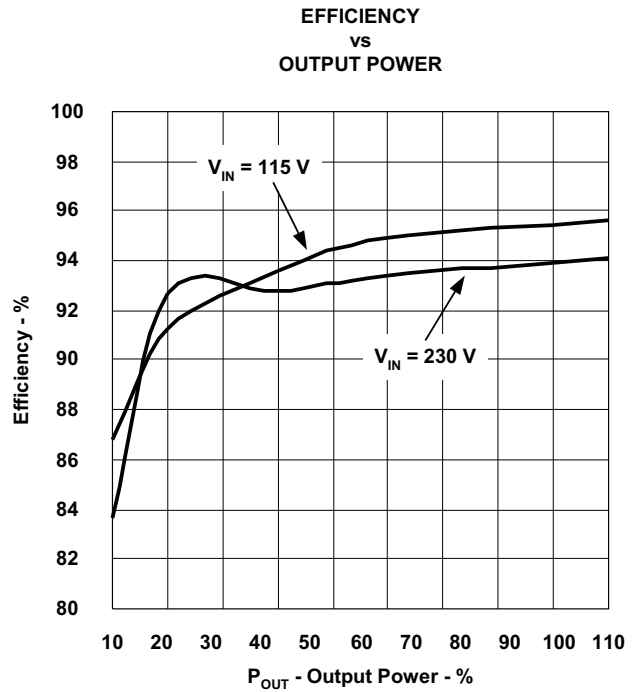

Figure 5. Efficiency at  $V_{IN} = 115\text{ V}$  and  $230\text{ V RMS}$

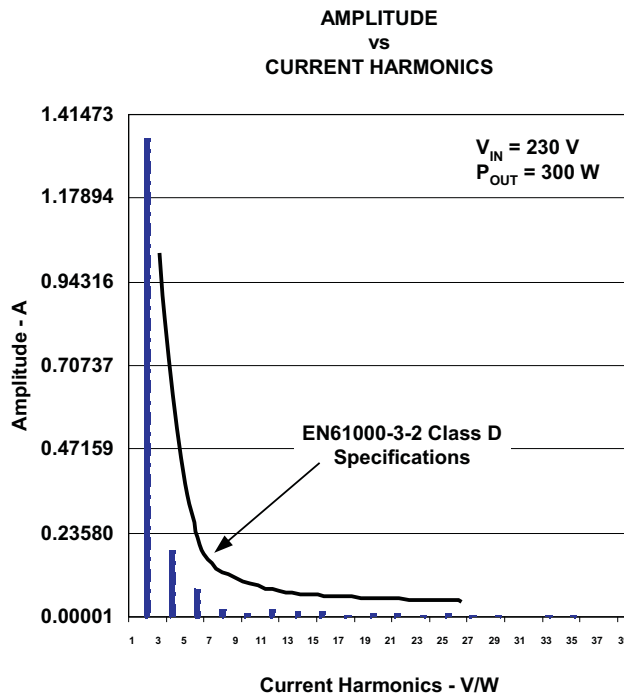
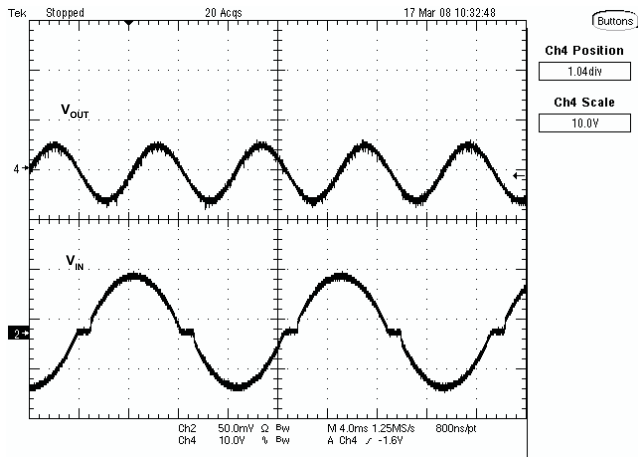
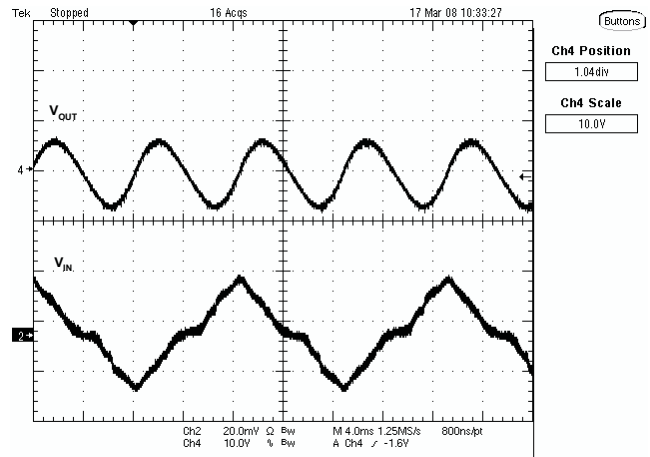

Figure 6. Input Current Harmonics at  $V_{IN} = 230\text{ V}$ ,  $P_{OUT} = 300\text{ W}$

### 8.1 Input Current and Output Ripple Voltage at Full Load



**Figure 7. Input Ripple Current ( $I_{IN}$ ), Output Ripple Voltage ( $V_{OUT}$ ),  $V_{IN} = 85 \text{ V RMS}$ ,  $P_{OUT} = 300 \text{ W}$**



**Figure 8. Input Ripple Current ( $I_{IN}$ ), Output Ripple Voltage ( $V_{OUT}$ ),  $V_{IN} = 265 \text{ V RMS}$ ,  $P_{OUT} = 300 \text{ W}$**

### 8.2 Input Ripple Current Cancellation

The following waveforms show input current ( $M1 = I_{L1} + I_{L2}$ ), Inductor Ripple Current ( $I_{L1}$ ,  $I_{L2}$ ) versus rectified line voltage. From these curves it can be observed that interleaving reduces the magnitude of input ripple current caused by the inductor ripple current.

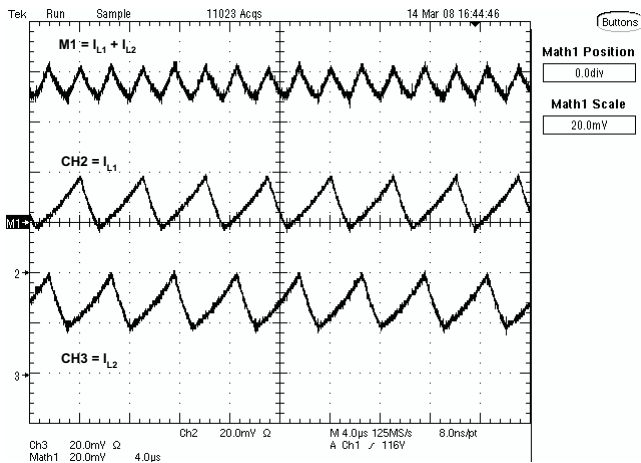

**Figure 9. Inductor and Input Ripple Current at  $V_{IN} = 85 \text{ V RMS}$  at the Peak of Line**

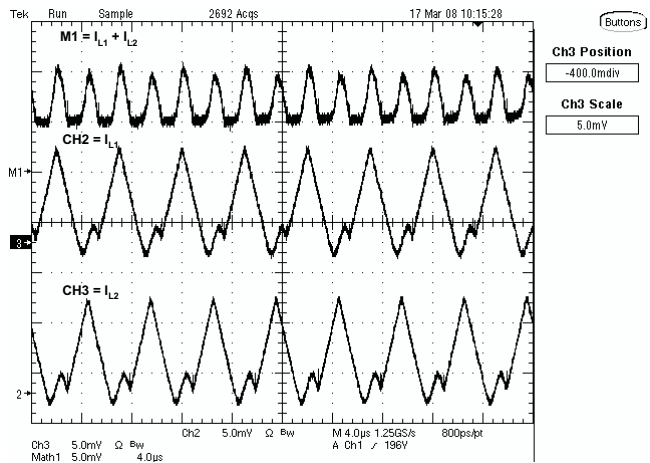

**Figure 10. Inductor and Input Ripple Current at 265 V RMS Input at the Half Output Voltage**

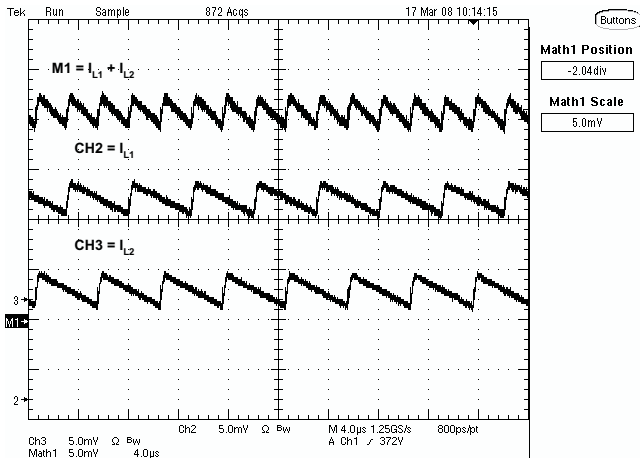

Figure 11. Inductor and Input Ripple Current at 265 V RMS Input at Peak of the Line Voltage

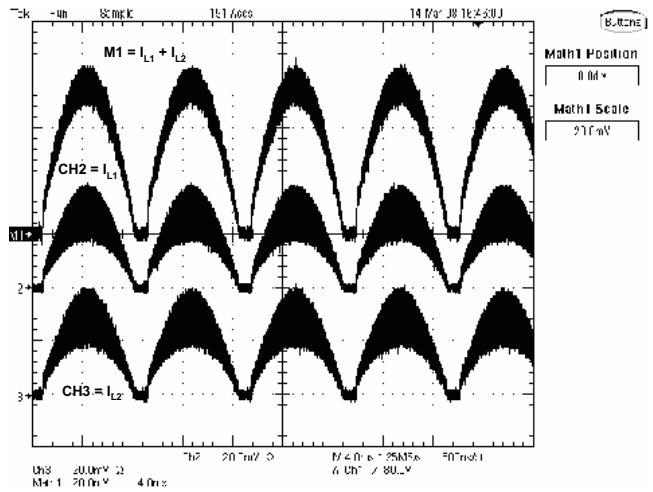

Figure 12. Input and Inductor Ripple Current at  $V_{IN} = 85$  V RMS,  $P_{OUT} = 300$  W

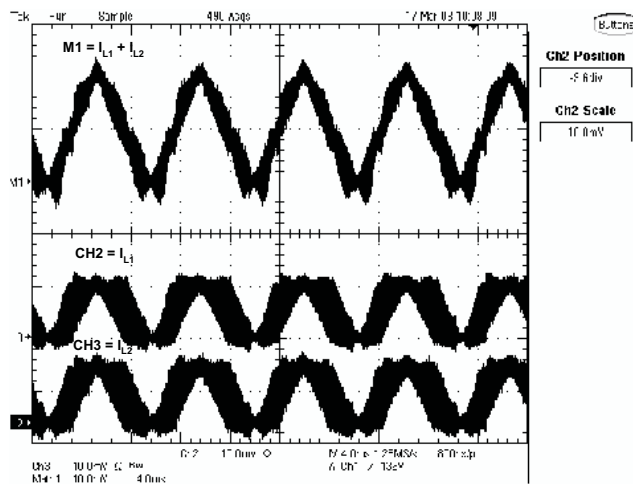

Figure 13. Input and Inductor Ripple Current at  $V_{IN} = 265$  V RMS,  $P_{OUT} = 300$  W



### 8.3 Startup Characteristics

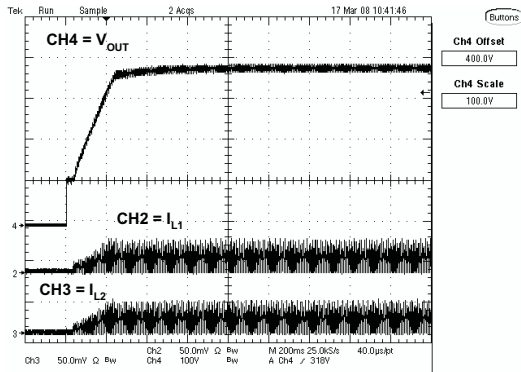

Figure 14. Start Up at  $V_{IN} = 85\text{ V}$ ,  $P_{OUT} = 300\text{ W}$

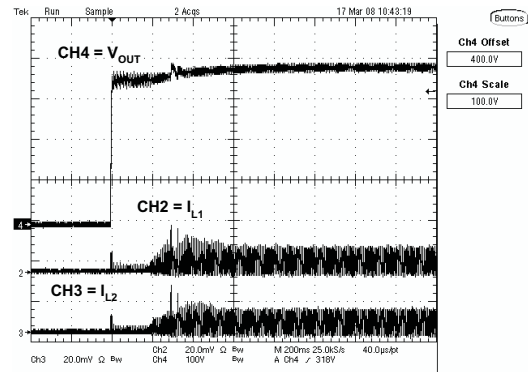

Figure 15. Start Up at  $V_{IN} = 265\text{ V}$ ,  $P_{OUT} = 300\text{ W}$

### 8.4 Line Dropout

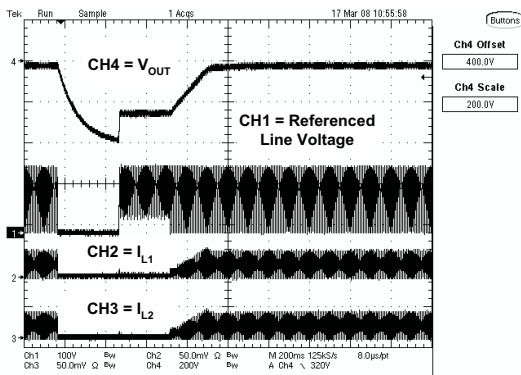

Figure 16. Line Dropout at 115 V RMS

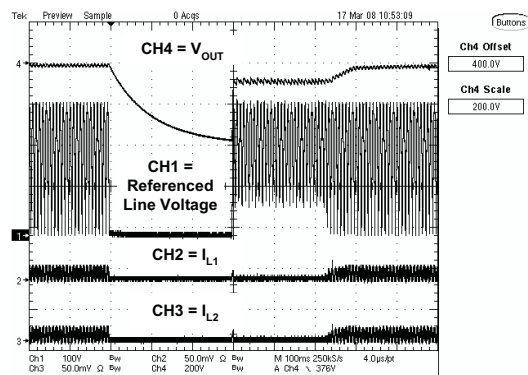

Figure 17. Line Dropout at 230 V RMS

### 8.5 Frequency Dithering

Frequency dithering has shown to reduce EMI. The UCC28070 EVM was design to operate in frequency dithering mode and none frequency dithering mode. When the JP1 and JP2 jumpers on the daughter board are shorted the PWM is operating in a fix frequency mode. The fixed frequency was set to 200 kHz per phase. When Jumpers JP1 and JP2 are open the converter is running in frequency dither mode. The single phases switching frequency was set to vary from roughly 190 kHz per phase to 210 kHz per phase.

When frequency dithering was applied to the EVM a 4.35 dBuV reduction in the Quasi Peak (QP) EMI measurement was observed.

**Note:** A filter was added to the front end of the EVM to clean up some of the noise to take EMI data. Depending on the filter the amount of EMI will vary. Also, this filter was not setup to pass EMI requirements but to show frequency dithering can reduced EMI.

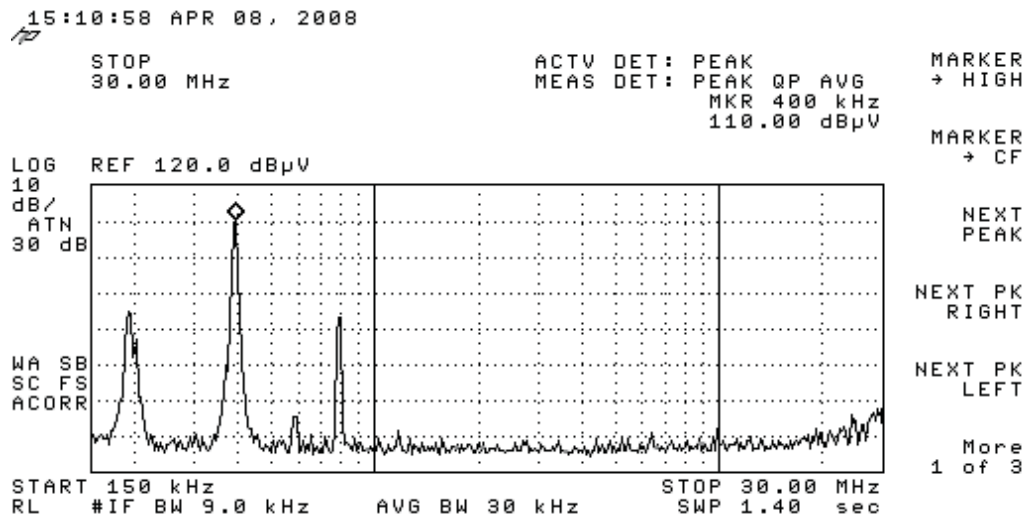

Figure 18. EMI Quasi Peak (QP) Measurement Without Frequency Dithering, No EMI Filter Present

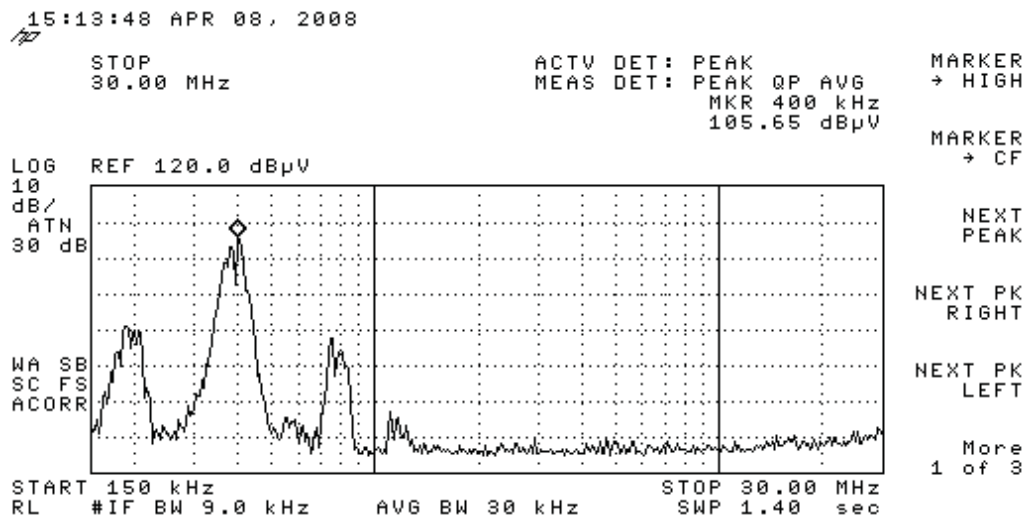

Figure 19. EMI Quasi Peak (QP) Measurement With Frequency Dithering, No EMI Filter Present

9 Reference Design Assembly Drawing

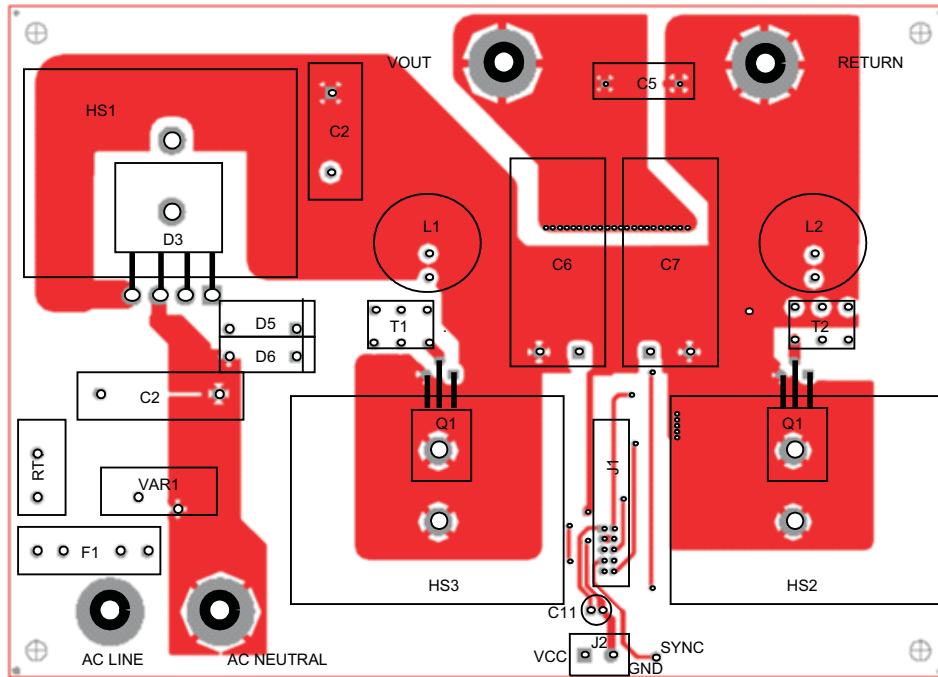

Figure 20. Mother Board, Top Assembly and Copper Layer

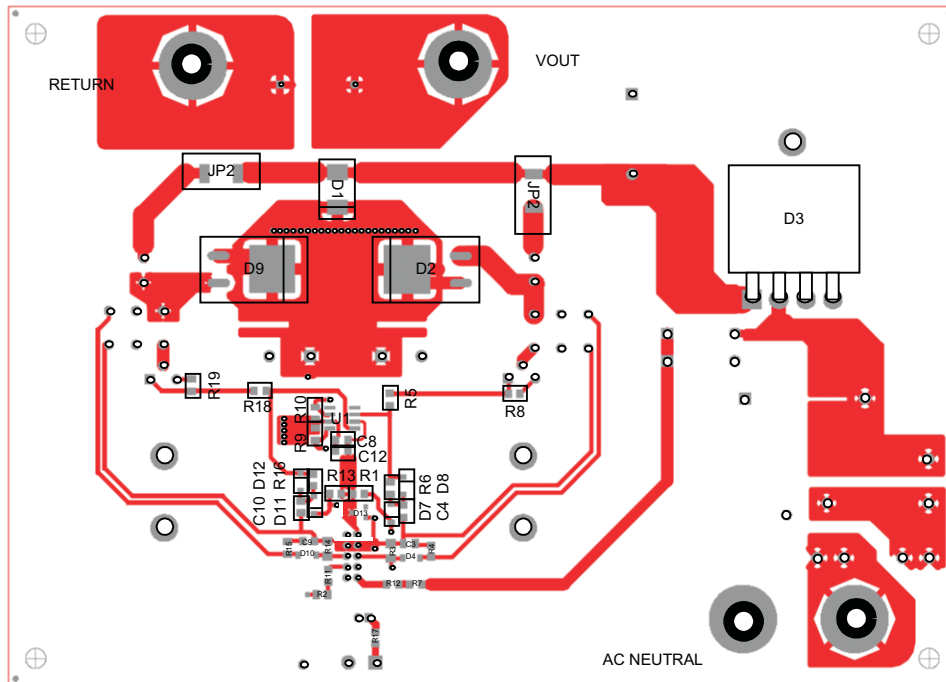

Figure 21. Mother Board, Bottom, Assembly and Copper Layer

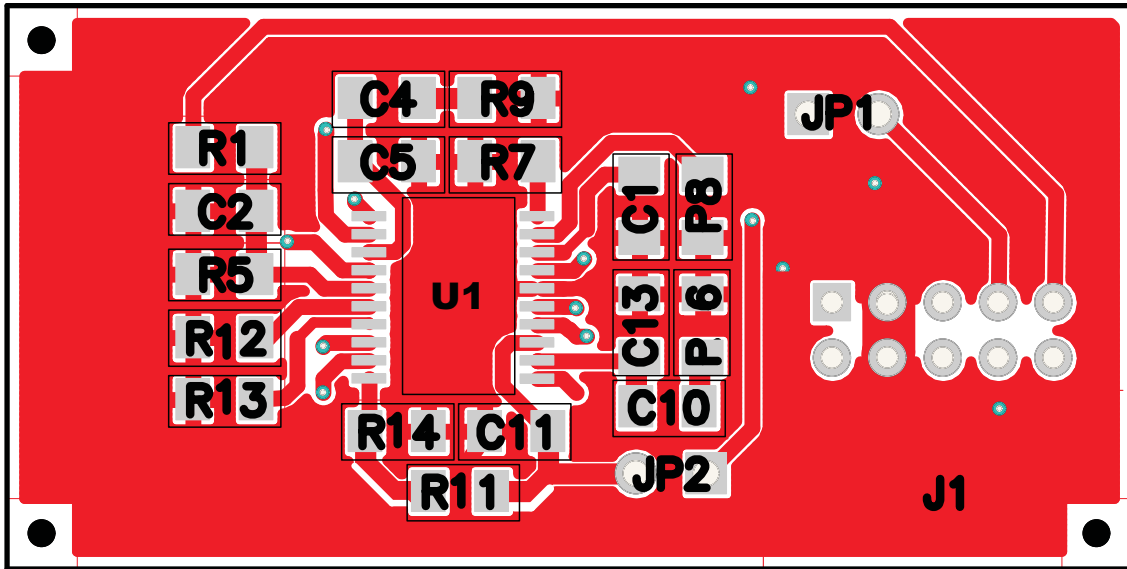

Figure 22. Daughter Board, Top Assembly and Copper Layer

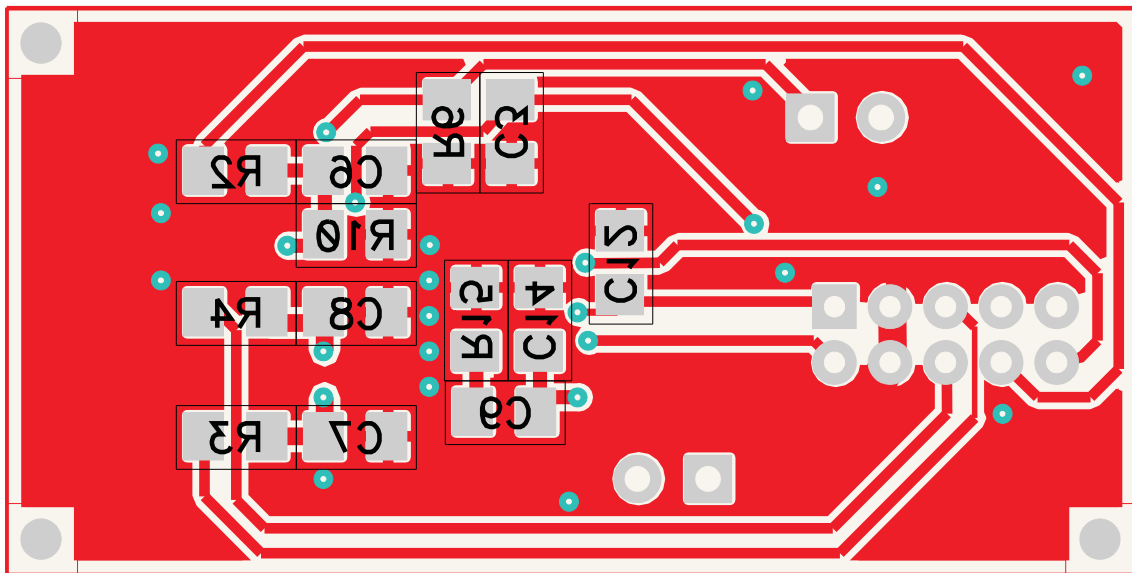

Figure 23. Daughter Board, Top Assembly and Copper Layer

## 10 List of Materials

### 10.1 Mother Board List of Materials

**Table 2. Mother Board**

COUNT	REF DES	DESCRIPTION	MFR	PART NUMBER
4	AC_LINE, AC_NEUTRAL, RETURN, VOUT	Connector, banana jack, uninsulated, 3267, 0.500 dia. inch	Pomona	3267
1	C1	Capacitor, film, 275 VAC, 20%, 0.1 $\mu$ F, 0.689 x 0.236 inch	Panasonic	ECQU2A104BC1
1	C11	Capacitor, aluminum, 35 V, 20%, 22 $\mu$ F, 0.200 * 0.435 inch	Panasonic	ECA-1VM220
1	C2	Capacitor, film, 275 VAC, 20%, 0.47 $\mu$ F, 0.236 X 0.591	Panasonic	ECQ-U2A474MG
2	C3, C9	Capacitor, ceramic, 25 V, X7R, 10%, 4.7 pF, 805	Std	Std
2	C4, C10	Capacitor, ceramic, 25 V, X7R, 10%, 47 nF, 805	Std	Std
1	C5	Capacitor, polyester, 630 V, 10%, 0.047 $\mu$ F, 0.256 x 0.650 inch	Panasonic	ECQ-E6473KZ
2	C6, C7	Capacitor, aluminum, 450 VDC, 20%, 100 $\mu$ F, 18 x 40 mm	Nippon Chemi-con	EKXG451ELL101MM4 0S
2	C8, C12	Capacitor, ceramic, 25 V, X7R, 10%, 100 nF, 805	Std	Std
1	D1	Diode, 3000 mA, 600 V, SMC	Vishay	S3J-E3/57T
1	D13	Diode, zener, 13 V, 300 mW, SOT-23	Diodes	BZX84C13-7
2	D2, D9	Diode, Schottky Rectifier, 10 A, 600 V, TO-263-2	CREE	CSD10060G
1	D3	Diode, bridge, 6 A, 600 V, BU6	Vishay	GBU6J
6	D4, D7, D8, D10, D11, D12	Diode, signal, 200 mA, 100 V, 350 mW, SOD-123	Diodes	1N4148W
2	D5, D6	Diode, signal, 600 V, 1 A , DO-41	Diodes	1N4005
1	F1	Fuse clip, 5x20 mm, 4 A/250 V fuse, 0.205 x 0.220 inch x2	Wickmann	0100056H
3	HS1, HS2, HS3	Heat sink, universal-mount TO-220, 1.500 x 2.000 inch	IERC-CTS	7-345-2PP
1	J1	Receptacle, 10 pins, 0.200 x 0.472 inch	HRS	DF11-10DS-2DSA(05)
1	J1	Assembled daughter board controller, HPA284	Std	Std
1	J2	Terminal block, 2 pin, 15 A, 5.1 mm, 0.40 x 0.35 inch	OST	ED1609
2	JP1, JP2	Resistor, chip, 1 W, 5%, 0, 2512	Std	Std
2	L1, L2	Inductor, 140 $\mu$ H at 3.2 A pk, 0.828 dia. inch	Cooper	CTX16-18405R
1	PCB	Printed circuit board, HPA225	Std	Std
2	Q1, Q2	MOSFET, N-channel, 500 V, 11 A, 520 m $\Omega$ , TO-220V	IR	IRFB11N50APbF
2	R1, R13	Resistor, chip, 1/10 W, 1%, 2.05 k $\Omega$ , 805	Std	Std
1	R17	Resistor, chip, 1/10 W, 1%, 20.5 $\Omega$ , 805	Std	Std
4	R2, R7, R11, R12	Resistor, chip, 1/10 W, 1%, 1.00 M $\Omega$ , 805	Std	Std
2	R3, R14	Resistor, chip, 1/8 W, 1%, 33.2 $\Omega$ , 1206	Std	Std
2	R4, R15	Resistor, chip, 1/10 W, 1%, 1.00 k $\Omega$ , 805	Std	Std
2	R5, R18	Resistor, chip, 1/10 W, 1%, 5.11 $\Omega$ , 805	Std	Std
2	R6, R16	Resistor, chip, 1/10 W, 1%, 2.49 k $\Omega$ , 805	Std	Std
4	R8, R9, R10, R19	Resistor, chip, 1/10 W, 1%, 10.0 k $\Omega$ , 805	Std	Std
1	RT1	Thermistor, NTC, 5 $\Omega$ , 6 A, 5 $\Omega$ , 0.180 X 0.550 inch	Thermometrics	CL-40

**Table 2. Mother Board (continued)**

COUNT	REF DES	DESCRIPTION	MFR	PART NUMBER
2	T1, T2	Inductor, 140 $\mu$ H at 3.2 A PK, 0.360 X 0.520 inch	Cooper	CTX16-18294-R
1	U1	Device, High Speed Low Side Power MOSFET Driver, SO8	TI	UCC27324D
1	VAR1	Varistor 275 V RMS, 0.472 x 0.213 inch	Epcos	S10K275E2
<b>Additional Hardware</b>				
1	X1 @ F1	4 A, fast acting fuse, 5 mm X 20 mm	Cooper/Bussman	BK/S501-4-R
6	X1 @ HS1 and D3, HS2 and Q1, HS3 and Q2	Nut #4-40 (steel)	Std	Std
6	X1 @ HS1 and D3, HS2 and Q1, HS3 and Q2	Pan head screw #4-40X3/8 (steel)	Std	Std
1	X1 D3 and HS1	Thermal grease	Std	Std
6	X1 @ HS1 and D3, HS2 and Q1, HS3 and Q2	Split lock washer #4(steel)	Std	Std
4	X1 @ HS1 and D3, HS2 and Q1, HS3 and Q2	Nylon shoulder washer #4	Keystone Electronics	3049
2	X1 @ HS2 and Q1, HS3 and Q2	Thermal pad silicon TO220	BERQUIST	3223-07FR-51
4	X1 @ HS2, HS3 None FET Side, Top and Bottom	External tooth washer #4	Std	Std

## 10.2 Daughter Board List of Materials

**Table 3. Daughter Board**

COUNT	REF DES	DESCRIPTION	PART NUMBER	MFR
1	C1	Capacitor, ceramic, 25 V, X7R, 10%, 1 $\mu$ F, 805	Std	Std
2	C11, C12	Capacitor, ceramic, 25 V, X7R, 10%, 100 nF, 805	Std	Std
2	C13, C14	Capacitor, ceramic, 25 V, X7R, 10%, 330 pF, 805	Std	Std
1	C2	Capacitor, ceramic, 25 V, X7R, 10%, 1.2 nF, 805	Std	Std
1	C3	Capacitor, ceramic, 25 V, X7R, 10%, 150 pF, 805	Std	Std
1	C4	Capacitor, ceramic, 25 V, X7R, 10%, 1.5 $\mu$ F, 805	Std	Std
1	C5	Capacitor, ceramic, 25 V, X7R, 10%, 150 nF, 805	Std	Std
1	C6	Capacitor, ceramic, 25 V, X7R, 10%, 3.3 nF, 805	Std	Std
2	C7, C8	Capacitor, ceramic, 25 V, X7R, 10%, 220 pF, 805	Std	Std
2	C9, C10	Capacitor, ceramic, 25 V, X7R, 10%, 2.2 nF, 805	Std	Std
1	J1	Header, right angle 10 pins, DF11-10DP-2DSxx, 0.394 x 0.472 inch	DF11-10DP-2DSxx	HRS
2	JP1, JP2	Header, 2 pin, 100 mil spacing, (36-pin strip), 0.100 inch x 2	PTC36SAAN	Sullins
2	JP1, JP2	Sockets jumper closed black	151-8010	Kobiconn
1	PCB	Daughter board PCB, HPA284	Std	Std
2	R1, R2	Resistor, chip, 1/10 W, 1%, 1.00 M $\Omega$ , 805	Std	Std
1	R11	Resistor, chip, 1/10 W, 1%, 3.65 k $\Omega$ , 805	Std	Std
1	R12	Resistor, chip, 1/10 W, 1%, 19.6 k $\Omega$ , 805	Std	Std
1	R13	Resistor, chip, 1/10 W, 1%, 38.30 k $\Omega$ , 805	Std	Std
1	R14	Resistor, chip, 1/10 W, 1%, 5.62 k $\Omega$ , 805	Std	Std
2	R15, R16	Resistor, chip, 1/10 W, 1%, 4.02 k $\Omega$ , 805	Std	Std
2	R3, R4	Resistor, chip, 1/10 W, 1%, 1.00 k $\Omega$ , 805	Std	Std
2	R5, R10	Resistor, chip, 1/10 W, 1%, 23.20 k $\Omega$ , 805	Std	Std
1	R6	Resistor, chip, 1/10 W, 1%, 46.40 k $\Omega$ , 805	Std	Std
1	R7	Resistor, chip, 1/10 W, 1%, 34.80 k $\Omega$ , 805	Std	Std
1	R8	Resistor, chip, 1/10 W, 1%, 37.40 k $\Omega$ , 805	Std	Std
1	R9	Resistor, chip, 1/10 W, 1%, 100.00 k $\Omega$ , 805	Std	Std
1	U1	Device, Two- Phases Interleaved CCM PFC Controller, TSSOP-20	UCC28070PW	TI

## EVALUATION BOARD/KIT IMPORTANT NOTICE

Texas Instruments (TI) provides the enclosed product(s) under the following conditions:

This evaluation board/kit is intended for use for **ENGINEERING DEVELOPMENT, DEMONSTRATION, OR EVALUATION PURPOSES ONLY** and is not considered by TI to be a finished end-product fit for general consumer use. Persons handling the product(s) must have electronics training and observe good engineering practice standards. As such, the goods being provided are not intended to be complete in terms of required design-, marketing-, and/or manufacturing-related protective considerations, including product safety and environmental measures typically found in end products that incorporate such semiconductor components or circuit boards. This evaluation board/kit does not fall within the scope of the European Union directives regarding electromagnetic compatibility, restricted substances (RoHS), recycling (WEEE), FCC, CE or UL, and therefore may not meet the technical requirements of these directives or other related directives.

Should this evaluation board/kit not meet the specifications indicated in the User's Guide, the board/kit may be returned within 30 days from the date of delivery for a full refund. **THE FOREGOING WARRANTY IS THE EXCLUSIVE WARRANTY MADE BY SELLER TO BUYER AND IS IN LIEU OF ALL OTHER WARRANTIES, EXPRESSED, IMPLIED, OR STATUTORY, INCLUDING ANY WARRANTY OF MERCHANTABILITY OR FITNESS FOR ANY PARTICULAR PURPOSE.**

The user assumes all responsibility and liability for proper and safe handling of the goods. Further, the user indemnifies TI from all claims arising from the handling or use of the goods. Due to the open construction of the product, it is the user's responsibility to take any and all appropriate precautions with regard to electrostatic discharge.

**EXCEPT TO THE EXTENT OF THE INDEMNITY SET FORTH ABOVE, NEITHER PARTY SHALL BE LIABLE TO THE OTHER FOR ANY INDIRECT, SPECIAL, INCIDENTAL, OR CONSEQUENTIAL DAMAGES.**

TI currently deals with a variety of customers for products, and therefore our arrangement with the user **is not exclusive.**

TI assumes **no liability for applications assistance, customer product design, software performance, or infringement of patents or services described herein.**

Please read the User's Guide and, specifically, the Warnings and Restrictions notice in the User's Guide prior to handling the product. This notice contains important safety information about temperatures and voltages. For additional information on TI's environmental and/or safety programs, please contact the TI application engineer or visit [www.ti.com/esh](http://www.ti.com/esh).

No license is granted under any patent right or other intellectual property right of TI covering or relating to any machine, process, or combination in which such TI products or services might be or are used.

### FCC Warning

This evaluation board/kit is intended for use for **ENGINEERING DEVELOPMENT, DEMONSTRATION, OR EVALUATION PURPOSES ONLY** and is not considered by TI to be a finished end-product fit for general consumer use. It generates, uses, and can radiate radio frequency energy and has not been tested for compliance with the limits of computing devices pursuant to part 15 of FCC rules, which are designed to provide reasonable protection against radio frequency interference. Operation of this equipment in other environments may cause interference with radio communications, in which case the user at his own expense will be required to take whatever measures may be required to correct this interference.

### EVM WARNINGS AND RESTRICTIONS

It is important to operate this EVM within the input voltage range of and the output voltage range of .

Exceeding the specified input range may cause unexpected operation and/or irreversible damage to the EVM. If there are questions concerning the input range, please contact a TI field representative prior to connecting the input power.

Applying loads outside of the specified output range may result in unintended operation and/or possible permanent damage to the EVM. Please consult the EVM User's Guide prior to connecting any load to the EVM output. If there is uncertainty as to the load specification, please contact a TI field representative.

During normal operation, some circuit components may have case temperatures greater than . The EVM is designed to operate properly with certain components above as long as the input and output ranges are maintained. These components include but are not limited to linear regulators, switching transistors, pass transistors, and current sense resistors. These types of devices can be identified using the EVM schematic located in the EVM User's Guide. When placing measurement probes near these devices during operation, please be aware that these devices may be very warm to the touch.

Mailing Address: Texas Instruments, Post Office Box 655303, Dallas, Texas 75265  
Copyright © 2008, Texas Instruments Incorporated



## IMPORTANT NOTICE

Texas Instruments Incorporated and its subsidiaries (TI) reserve the right to make corrections, modifications, enhancements, improvements, and other changes to its products and services at any time and to discontinue any product or service without notice. Customers should obtain the latest relevant information before placing orders and should verify that such information is current and complete. All products are sold subject to TI's terms and conditions of sale supplied at the time of order acknowledgment.

TI warrants performance of its hardware products to the specifications applicable at the time of sale in accordance with TI's standard warranty. Testing and other quality control techniques are used to the extent TI deems necessary to support this warranty. Except where mandated by government requirements, testing of all parameters of each product is not necessarily performed.

TI assumes no liability for applications assistance or customer product design. Customers are responsible for their products and applications using TI components. To minimize the risks associated with customer products and applications, customers should provide adequate design and operating safeguards.

TI does not warrant or represent that any license, either express or implied, is granted under any TI patent right, copyright, mask work right, or other TI intellectual property right relating to any combination, machine, or process in which TI products or services are used. Information published by TI regarding third-party products or services does not constitute a license from TI to use such products or services or a warranty or endorsement thereof. Use of such information may require a license from a third party under the patents or other intellectual property of the third party, or a license from TI under the patents or other intellectual property of TI.

Reproduction of TI information in TI data books or data sheets is permissible only if reproduction is without alteration and is accompanied by all associated warranties, conditions, limitations, and notices. Reproduction of this information with alteration is an unfair and deceptive business practice. TI is not responsible or liable for such altered documentation. Information of third parties may be subject to additional restrictions.

Resale of TI products or services with statements different from or beyond the parameters stated by TI for that product or service voids all express and any implied warranties for the associated TI product or service and is an unfair and deceptive business practice. TI is not responsible or liable for any such statements.

TI products are not authorized for use in safety-critical applications (such as life support) where a failure of the TI product would reasonably be expected to cause severe personal injury or death, unless officers of the parties have executed an agreement specifically governing such use. Buyers represent that they have all necessary expertise in the safety and regulatory ramifications of their applications, and acknowledge and agree that they are solely responsible for all legal, regulatory and safety-related requirements concerning their products and any use of TI products in such safety-critical applications, notwithstanding any applications-related information or support that may be provided by TI. Further, Buyers must fully indemnify TI and its representatives against any damages arising out of the use of TI products in such safety-critical applications.

TI products are neither designed nor intended for use in military/aerospace applications or environments unless the TI products are specifically designated by TI as military-grade or "enhanced plastic." Only products designated by TI as military-grade meet military specifications. Buyers acknowledge and agree that any such use of TI products which TI has not designated as military-grade is solely at the Buyer's risk, and that they are solely responsible for compliance with all legal and regulatory requirements in connection with such use.

TI products are neither designed nor intended for use in automotive applications or environments unless the specific TI products are designated by TI as compliant with ISO/TS 16949 requirements. Buyers acknowledge and agree that, if they use any non-designated products in automotive applications, TI will not be responsible for any failure to meet such requirements.

Following are URLs where you can obtain information on other Texas Instruments products and application solutions:

### Products

Amplifiers	<a href="http://amplifier.ti.com">amplifier.ti.com</a>
Data Converters	<a href="http://dataconverter.ti.com">dataconverter.ti.com</a>
DSP	<a href="http://dsp.ti.com">dsp.ti.com</a>
Clocks and Timers	<a href="http://www.ti.com/clocks">www.ti.com/clocks</a>
Interface	<a href="http://interface.ti.com">interface.ti.com</a>
Logic	<a href="http://logic.ti.com">logic.ti.com</a>
Power Mgmt	<a href="http://power.ti.com">power.ti.com</a>
Microcontrollers	<a href="http://microcontroller.ti.com">microcontroller.ti.com</a>
RFID	<a href="http://www.ti-rfid.com">www.ti-rfid.com</a>
RF/IF and ZigBee® Solutions	<a href="http://www.ti.com/lprf">www.ti.com/lprf</a>

### Applications

Audio	<a href="http://www.ti.com/audio">www.ti.com/audio</a>
Automotive	<a href="http://www.ti.com/automotive">www.ti.com/automotive</a>
Broadband	<a href="http://www.ti.com/broadband">www.ti.com/broadband</a>
Digital Control	<a href="http://www.ti.com/digitalcontrol">www.ti.com/digitalcontrol</a>
Medical	<a href="http://www.ti.com/medical">www.ti.com/medical</a>
Military	<a href="http://www.ti.com/military">www.ti.com/military</a>
Optical Networking	<a href="http://www.ti.com/opticalnetwork">www.ti.com/opticalnetwork</a>
Security	<a href="http://www.ti.com/security">www.ti.com/security</a>
Telephony	<a href="http://www.ti.com/telephony">www.ti.com/telephony</a>
Video & Imaging	<a href="http://www.ti.com/video">www.ti.com/video</a>
Wireless	<a href="http://www.ti.com/wireless">www.ti.com/wireless</a>

Mailing Address: Texas Instruments, Post Office Box 655303, Dallas, Texas 75265  
Copyright © 2008, Texas Instruments Incorporated